

Timber Window Repairs

Traditional timber windows are of several types, usually described in terms relating to the type of sash (i.e. the separate light frame of a window carrying the glass). For example:

- (i) Casement sash, usually hinged on the side of frame.
- (ii) Awning sash, frequently hinged on the top of frame.
- (iii) Double hung sashes; two sashes which slide vertically in a 'box frame' or 'solid frame', the weight of the sashes balanced by counter weights or springs.
- (iv) Miscellaneous: hopper, centre pivot, sliding, etc.

Repairs to some of these windows often only requires replacement of rusted hinges, locking devices or friction stays, pivot winders or similar. Repairs of this type are relatively simple since all that is usually required is to unscrew the old unit or fitting and re-fit another identical fitting in its place.

Decayed or rotted timber sashes: Where the timber has deteriorated and has decayed, the repair could require re-fitting segments of the frame(s) using mortice and tenon joints and could be considered beyond a simple handyman task. Complete replacement of the damaged sash should be considered, and sizes, prices, etc., discussed with one of the many timber joinery works.

Cracked, split or broken frames in the window sometimes may be repairable using wood adhesives and clamps. Use water/weatherproof adhesive if the repaired part would be exposed to rain and sun. (Resorcinol Formaldehyde or Melamine-Formaldehyde Adhesive or similar boat building glues could be used.) Rusted and/or ineffective screws on fittings can be replaced, in some cases, by slightly larger diameter screws, by parallel thread metal thread, 'self tappers'), or by longer screws. If available, use non-corroding fittings and screws.

If none of these above simple remedies are effective, then consider removing the damaged/rusted area of wood around the screw(s) by drilling a hole sufficiently large to accept a short section of dowelling. Fit and glue dowelling in place, pre-drill screw holes as required, prime and paint dowels and re-fix the fitting.

You should discuss your need with your timber/hardware merchant if none of these ideas appeal. Particularly investigate the range of putties, fillers, adhesives, sealants available.

For example, a useful material for quick repairs of eroded screw holes and of minor damage to timber, etc. is epoxy putty. This is a two-part mixture, usually grey when mixed, which must be prepared according to instructions of the manufacturer. It is useful to fill small holes, provided all loose or powdery or deteriorated timber or metal is scraped off. Firm, clean surfaces are desirable and some time for hardening should be allowed before drilling, smoothing, re-painting and refitting screws, etc. Shrinkage of the hardened material is minimal.

Repair of damaged timber on the inside of windows (i.e. not exposed to rain and sun) can be frequently achieved using 'plastic wood' which is applied to the cleaned area and allowed to harden before sanding, shaping, drilling and painting. Several applications of plastic wood to large or deep dints, scratches, etc., may be required and allowance must be made for shrinkage of this filler as it hardens.

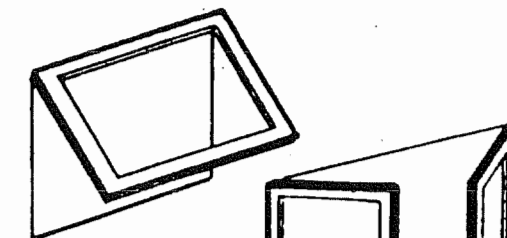

AWNING SASH, HOPPER
(TOP HINGED)

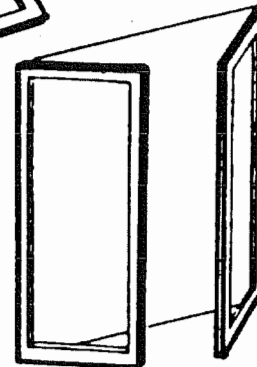

CASEMENT (SIDE HUNG)

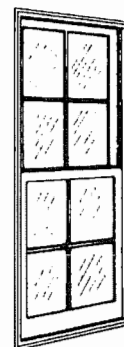

DOUBLE HUNG SASH

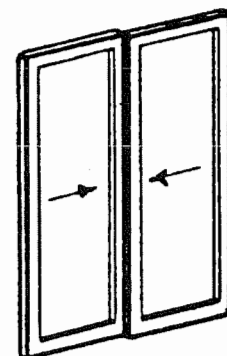

HORIZONTAL SLIDING

REPAIR BOX FRAME WINDOWS

The box frame window is frequently found in older houses. It is a traditional window comprising an upper and a lower sash which slide vertically in grooves or guides formed by parting beads and stop beads for lower sash, and parting bead and outside lining board for upper sash. (The parting bead separates or keeps the two sashes apart.)

The sashes are counter weighted by weights and cord or by a spring or friction system. Failure of the spring/spiral systems may occur and these units are then replaced by new units. Dismantling of the window sash to carry out this replacement is similar to that of removing sashes to replace sash cords as described later.

The diagrams (overleaf) show some parts of the box frame window referred to in this description of repairs.

Problems encountered with timber double hung box frame windows are:

- (i) **RATTLING WINDOWS:** Frequently occurs because of shrinkage or loose fitting in grooves. Remedy is to remove the stop beads (see diagrams) and refix them in position closer to the sash frame so that the looseness is eliminated.
- (ii) **LEAKING WINDOWS:** This may occur because of
 - (a) broken or cracked glass which should be replaced;
 - (b) eroded, cracked or missing putty on the exterior portion of the glass which should be replaced as instructed by the manufacturer of the putty, or
 - (c) badly fitted or designed bottom rail-to-sill shaping, or a bad joint at the meeting of top and bottom rails. Correction of these faults could be achieved by removing bottom sash and planing off the bottom of the rail;
 - (d) broken sash cords or spring balances on one side of sash which allows the sashes to twist in the frame, and allow water through the gap(s) made. The repair of this problem is a major task and is described in the following section.

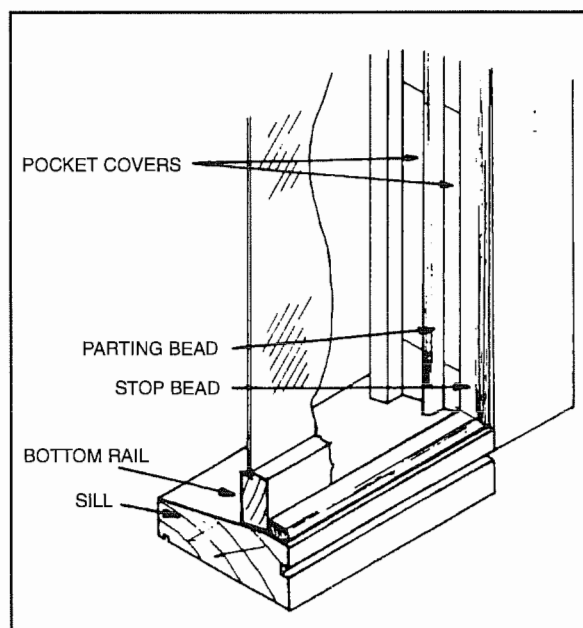

RENEWING SASH CORDS

Tools you will need

- Hammer
- Chisel
- Paint scraper/spatula
- Nail punch
- Pliers/nail pincers
- Knife, hacksaw blade

Materials you will need

TIMBER

(a) You may need to replace parting bead (see Sketch) if this cannot be removed without breaking. Measure thickness of original beading and purchase ready moulded bead, or plane down thicker beading or timber. The new bead should be well seasoned and it is essential that it fits tightly in groove.

(b) You may need to replace stop bead (see sketch) if this cannot be removed without breaking beyond re-use. Very old damaged beading could be difficult to match with new material, so consider replacing all stop beading with new moulding for a better finish.

HARDWARE

Sash cord, sufficient to replace damaged cords. Note: it is a good policy to replace all four cords at the same time since one broken cord usually indicates other cords of similar age could be about to break.

Galvanised clouts: 30 x 2.8mm for refastening cords.
40 x 2.5mm bullet head wire nails – for re-nailing stop beads.

STEP BY STEP

- 1** Remove stop bead from inside of windows using chisel or flat paint scraper and nail pincers as required. A hacksaw blade could be useful to cut off nails at each end of the beading.
- 2** Remove (lower) window sash. To do this, first raise the sash to top of window, then cut cord if necessary allowing weights to drop to bottom of pocket.
- 3** Remove parting bead. In many window assemblies this could require considerable effort to break away old paint. Use spatula, flat paint scraper, chisel or knife as necessary. The parting bead would not normally be nailed in place although in older windows previous repairs may have left small nails in the bead. Clean and smooth down parting bead for refitting.
- 4** Remove upper window sash by cutting old cord, etc. as required, while the sash is in the upper portion of the frame.
- 5** Remove old or broken cords from each of the sashes using pliers or pincers to remove the clouts.
- 6** Remove pocket piece or cover (see diagram) by levering upwards with chisel inserted at the bottom edge. In some box frames the bottom of this pocket piece is held in place by small nails or screws which must be withdrawn before the pocket piece can be removed.

7 Remove weights from pockets, clearly marking and identifying them so that they can be re-located in original pocket. Usually, heavier weights are used on upper sashes. Remove, as necessary, old sash cord from weights.

8 Refit sash cords. Replacement of all cords should be done in a sequence starting with the cords for the upper sash. A typical sequence would be:

(i) Run thin string weighted with a 50mm or 75mm nail over the appropriate pulley and down through pocket hole. Tie new sash cord to string and pull this over pulley, down and out through pocket hole.

(ii) Take the correct sash weight, insert sash cord through hole and tie figure-of-eight knot or similar and tighten. Replace weight in pocket.

(iii) Pull cord back through pulley, lifting weight to within 25mm of pulley. Temporarily nail cord at top of frame.

(iv) Locate window sash in bottom of frame (i.e. at lowest possible position) and attach cord in the same manner and position as originally fitted using galvanised clouts.

Note: the first clout should be about 150mm from top edge of sash; use three clouts per cord. Cut off excess cord.

(v) Repeat procedure on other side of upper sash and then on the two cords of the lower sash.

(vi) Remove temporary nails and check operation of windows.

9 Refit pocket pieces.

10 Refit parting bead by firmly tapping into place with hammer handle or wooden block.

Note: This bead should be a tight fit and if damaged, broken or splintered during removal, may require replacing with correctly thickened new material. Avoid nailing into position.

11 Refit stop beading, taking the opportunity to relocate closer to sashes if windows had previously rattled.

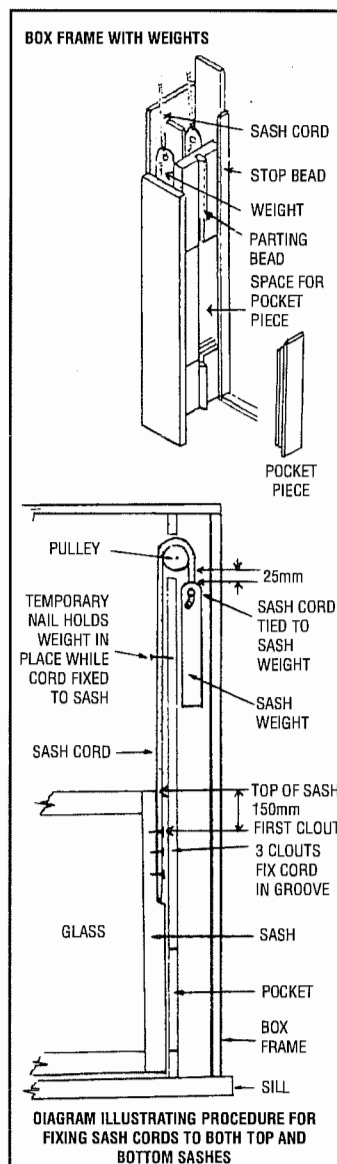

Supplied by