



QUICKFRAME

EASIEST & BEST GATE/PANEL FRAMING SYSTEM: SIMPLY SCREW ON CLADDING

- Height & width adjustable gate & panel frames
- Gates include hinges
- Constructed with durable galvanised steel
- Simply screw on timber, colourbond, aluminium etc
- Will not warp or shrink
- 100% termite proof, no need for chemicals

EASY DIY INSTALLATION

COMPLETE KIT READY TO TAKE AWAY

ADJUSTABLE GATE SYSTEM & PANEL

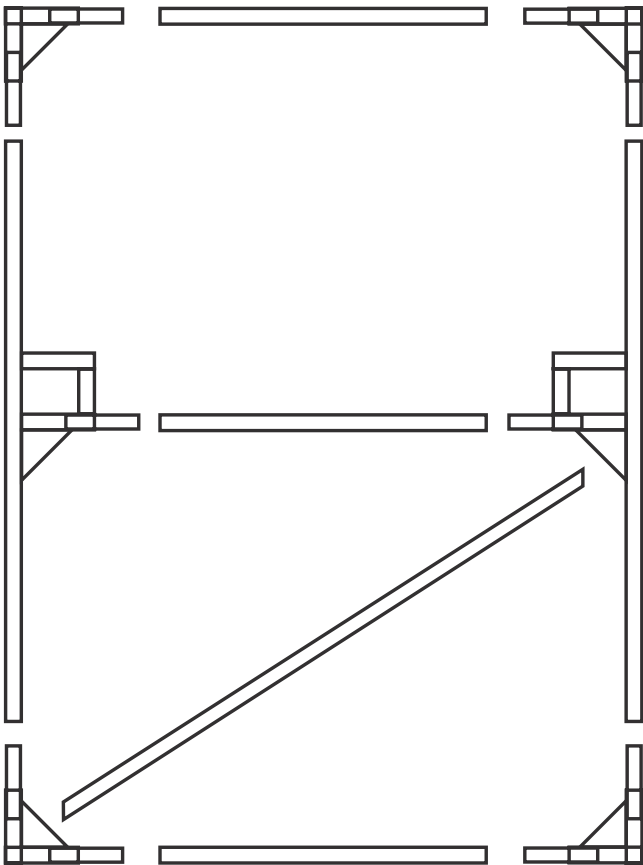

INSTALLED QUICKFRAME



GATE SIZES

W:1100 x H:1800mm - with pre-welded hinges

W:1800 x H:1200mm - with pre-welded hinges

W:1800 x H:1800mm - with pre-welded hinges

For more information contact our distributor:



WOODRIDGE:

206 Ewing Rd | P: 07 3386 0595 | E: woodridge@5startimbers.com.au

STAPYLTON:

25 Quarry Rd | P: 07 3386 1055 | E: stapylton@5startimbers.com.au

www.5startimbers.com.au



QUICKFRAME

ASSEMBLY GUIDE



STEP 1. Open your Quick Frame gate kit & assemble your frame.



STEP 2. Measure your opening & if required, make a simple straight cuts to alter gate height / width.



STEP 3. Re-assemble, confirm measurements & screw your Quick Frame gate kit together using the screws provided.



STEP 4. Hang your hinge receivers to post or wall.



STEP 5. Hang your Quick Frame gate to ensure correct fit.



STEP 6. Prepare your desired cladding.



STEP 7. Fix your gate or panel cladding to your Quick Frame gate or panel.

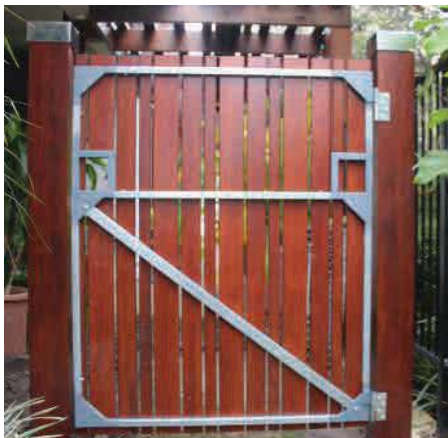

STEP 8. Re-hang your finished gate & attach your latch, lock or catch.



STEP 9. Enjoy.

For more information contact our distributor:



WOODRIDGE:

206 Ewing Rd | P: 07 3386 0595 | E: woodridge@5startimbers.com.au

STAPYLTON:

25 Quarry Rd | P: 07 3386 1055 | E: stapylton@5startimbers.com.au

www.5startimbers.com.au