

# Billy Cart

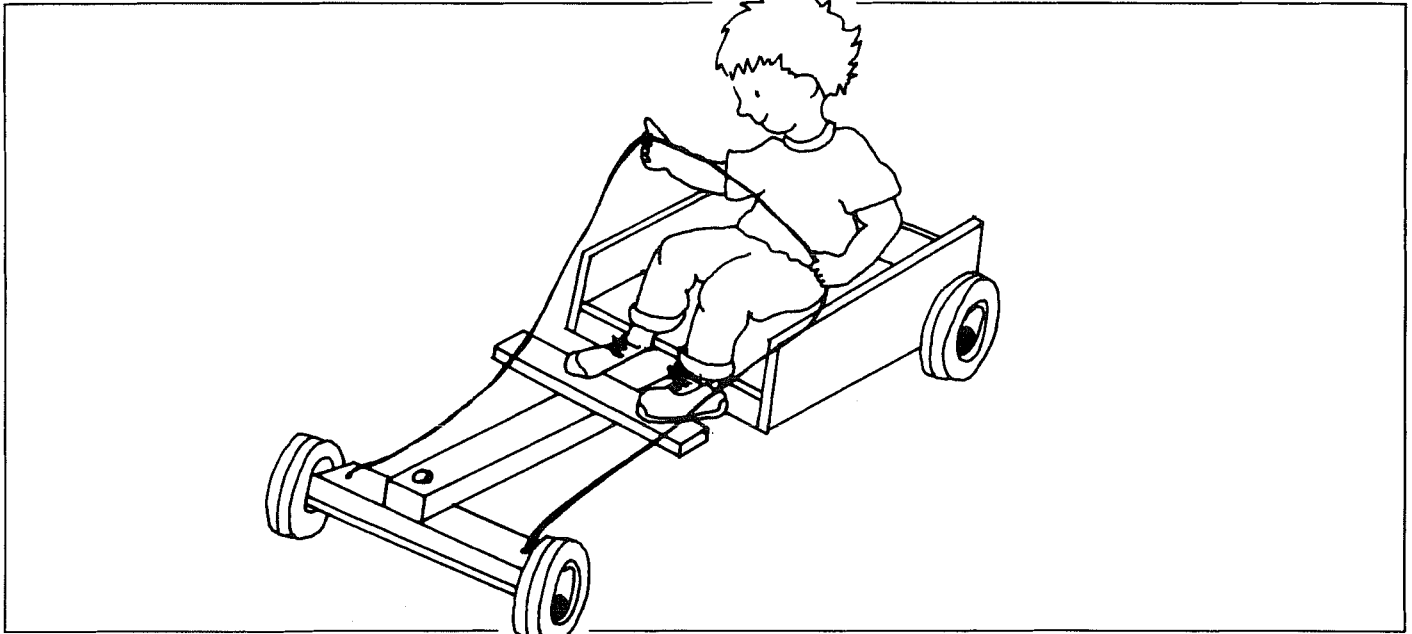
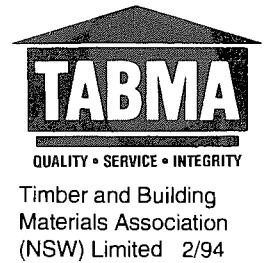

## Tools you will need

- Saw
- Carpenters square
- Marking pencil/scraper
- Rule/measuring tape
- Drill and Bits
- Hammer
- Wood chisel
- Spanners

## Materials you will need

### TIMBER QUALITY

Several different combinations of timber would be acceptable provided the components shown as A,B,C and D are sound, and are relatively free of strength reducing imperfections such as large knots, splits, etc. You may prefer to use Appearance grade timber.

Consult your TABMA Timber Merchant concerning availability of stock, dressed-all-round (DAR) timbers, seasoned or unseasoned, at least of structural quality. Some suppliers may be able to dress material to-order.

### TIMBER SIZES TO ORDER

- ◆ **75 x 50 mm DAR**  
2 pieces 600 mm for parts A, B (may need adjustment to suit axles/wheels selected)  
1 piece 1.2 m for Part D  
1 piece 380 mm for Part C
- ◆ **200 x 25 mm DAR**  
4 pieces 595 mm for Parts E, F
- ◆ **75 x 25 mm DAR**  
2 pieces 380 mm for parts G, H  
1 piece 90 mm for Part J

Note: Your TABMA Timber Merchant will provide sufficient timber from which the handyman can cut the lengths required. Some suppliers may offer a cut-to-size service for an additional charge, or you may need material cut so as to fit it in your car boot or cabin.

### HARDWARE

N.B. First select the axle plus wheel plus support brackets from your hardware supplier. Typically, axles of 600 mm lengths are available and suitable. At least two types of wheels could be available to fit on the axles.

- 2/600 mm x 12 mm axles and brackets
- 2/150 mm wheels to fit front axles
- 2/200 mm wheels to fit rear axles
- 4 split pins to fit axles
- 8/ washers to fit axles
- Screws/bolts supplied as kit with axle brackets OR, appropriate bolts to fix brackets to parts A,B.
- 1/115 mm (approx) x 9.5 mm hex. head bolt
- 2/9.5 mm nuts to fit bolts
- 4/9.5 mm washers
- 24/50 mm x 2.8 mm flat head nails
- 2/50 mm x 6 mm cup head bolt
- 2/6 mm washers
- 2/38 m x 3.15 wood screws
- 2 metres rope

**▼ STEP BY STEP ▼**

**1** Cut these from the 75 x 50 mm DAR

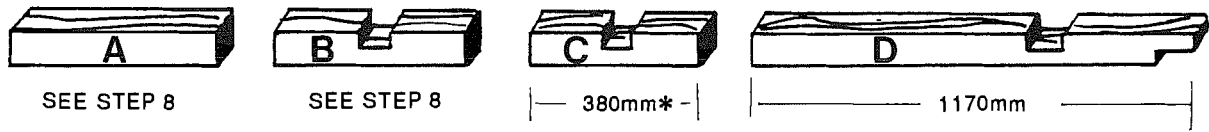

\* Note Dimension shown for C should equal width of seat made up of two widths of parts E

**2** Cut these from the 200 x 25 mm DAR timber

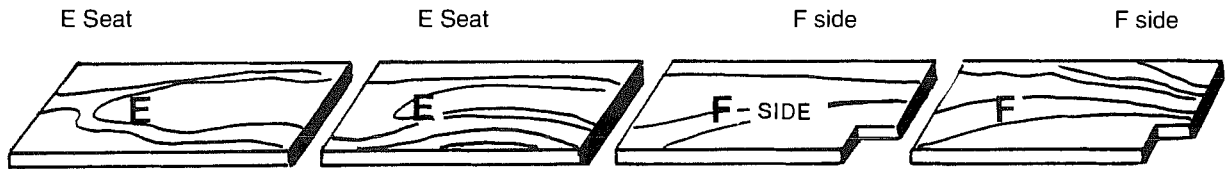

**3** Cut these from 75 x 25 mm DAR

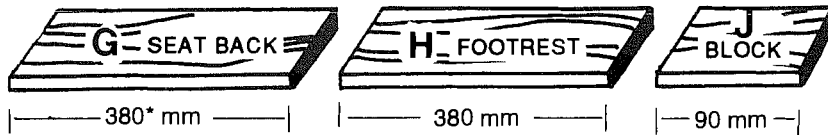

\* Note dimension G should be equal to width of Part C.

**4 Assembling frame:** Bolt pieces B and C to centre board 'D' as shown. Use 50 mm x 6 mm cup heads bolts, nuts and washers. Head of bolt must be on the top side of D. Ensure that B and C are at right angles (square) with D. To make a stronger joint use a standard PVA wood glue on these joints.

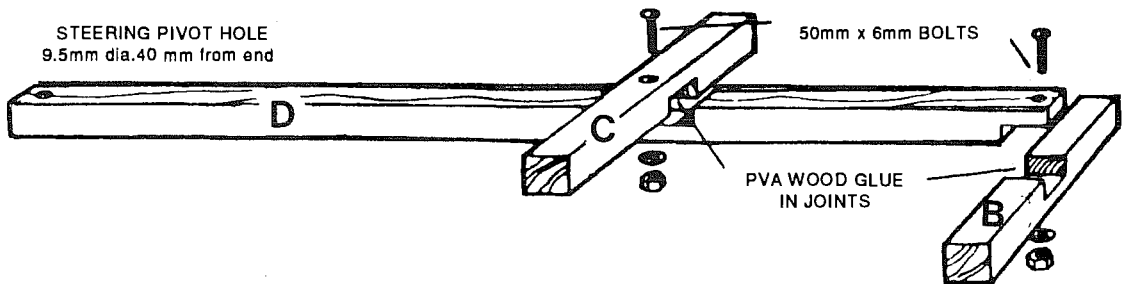

**5 Fitting wheel brackets:** Fix axle brackets to Part A and B, using screws/bolts as appropriate. Heads of bolts must be to the top side of Part D if used. Front wheel brackets must be positioned to allow rope holes on the forward part of Part A and so located that the axle position leaves pivot bolt and nuts accessible for adjustments.

BRACKET AND BOLT OR SCREW FIXINGS TO SUIT SELECTED WHEEL AXLE BRACKET SYSTEM

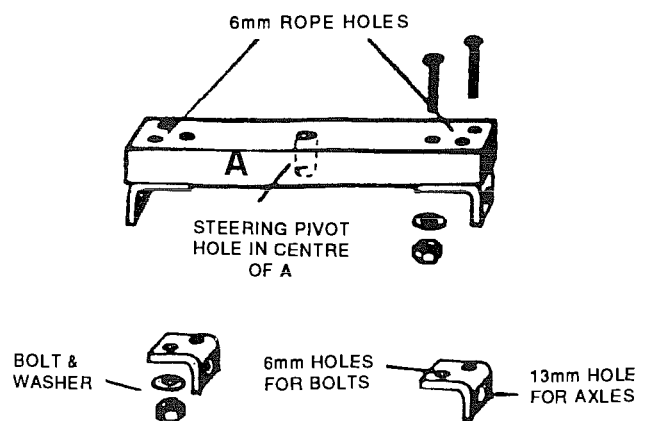
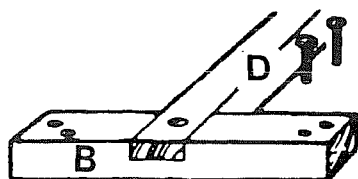

**6 Assembling steering:** Attach pieces, Part A to Part D using the 115 mm x 9.5 mm hexagonal bolt with washers and nuts as shown with locking nuts on top of Part D (first check that hex head clears axle you may need to sink it into bottom of Part A).

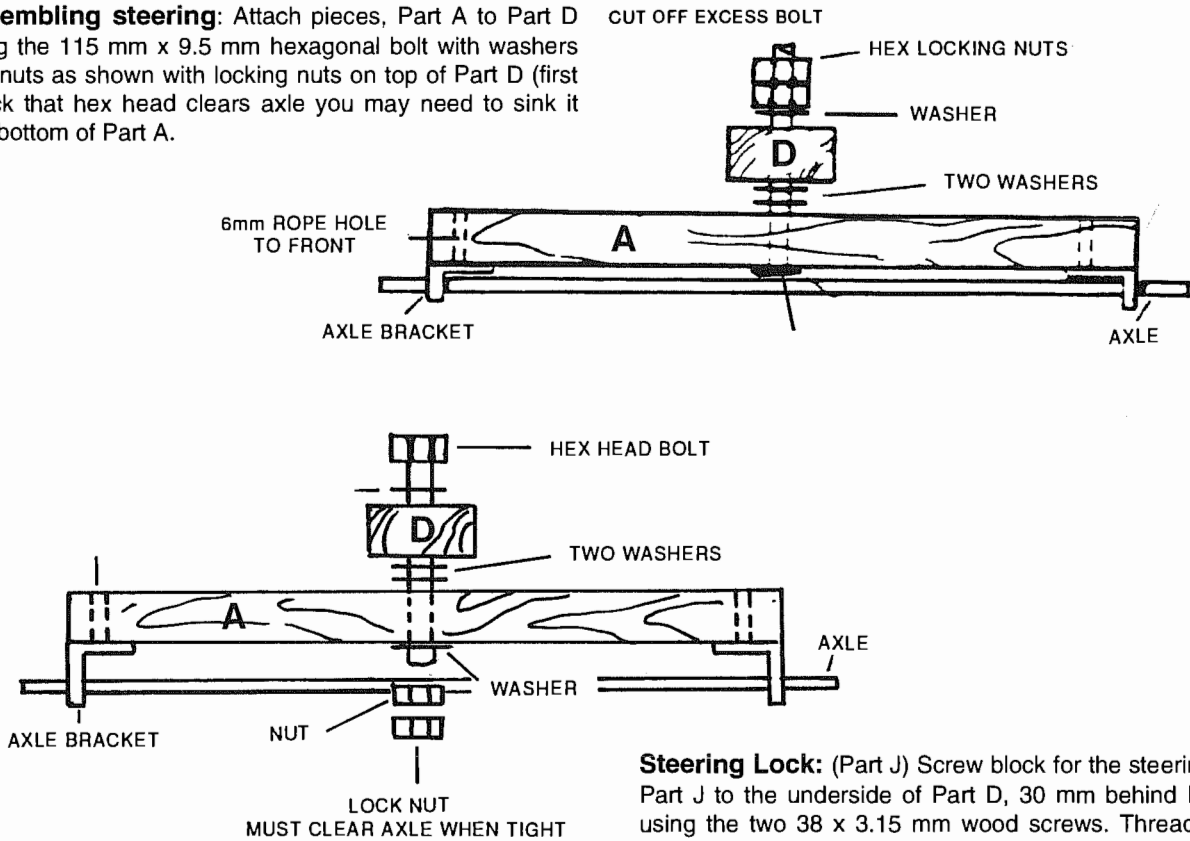

**Steering Lock:** (Part J) Screw block for the steering lock Part J to the underside of Part D, 30 mm behind Part A, using the two 38 x 3.15 mm wood screws. Thread Rope through holes in front edge of Part A and tie double knots on the underside of A.

**7 Fitting seat:** Nail the seat boards Parts E, on the cross braces, Parts C and B, such that the boards cover top side of Part C, fitting flush with front edge and side (or ends) of Part C, fitting flush with front edge and side (or ends) of Part C. Use four nails per board fixing firmly to Parts C and B. Nail sides (Parts F) into the edges of seat boards and into the ends of Part C. Note the cut-outs on side Part F are sized to fit closely over Part B. Use four nails per side. Nail seat back, Part G between sides F. The position of the seat back should be adjusted along the length of the side depending upon the size of the drivers. Use two nails each side of seat brace, nailing through side, Part F into ends of seat back, Part G.

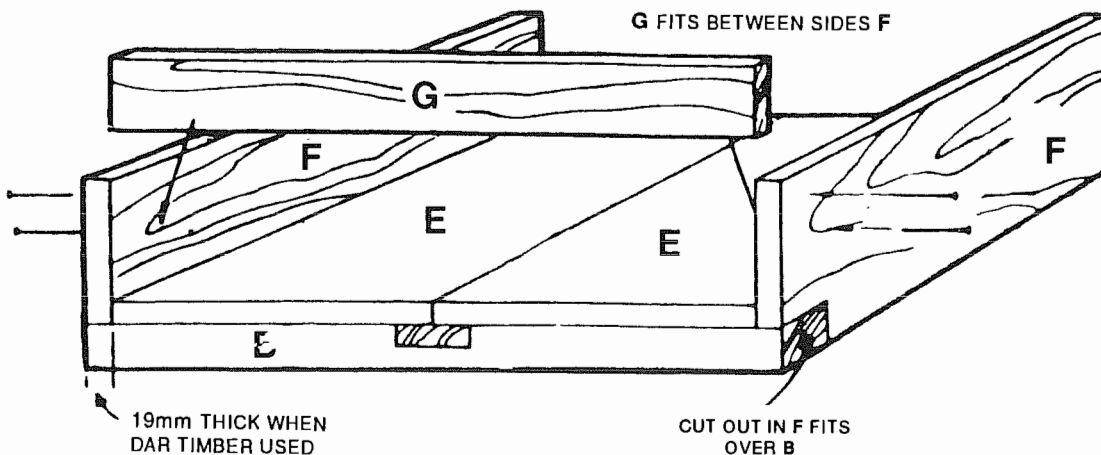
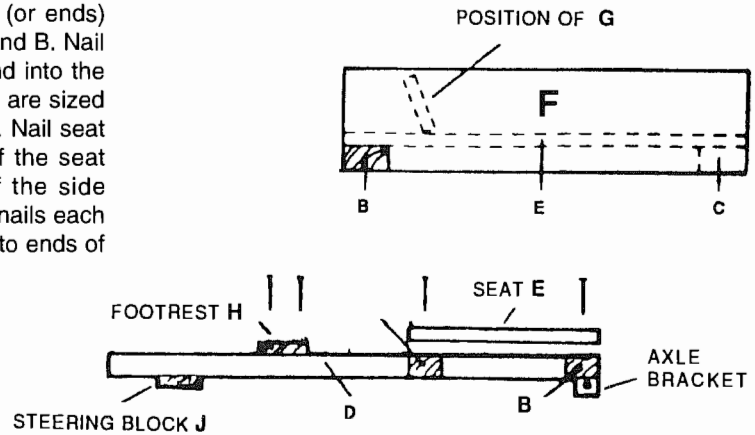

**8 Assembling wheels:** Slide larger diameter wheels on to rear axles, with metal bush to the inside, or use washers as shown. Finally, insert split pins and bend open. Repeat procedure for front wheels.

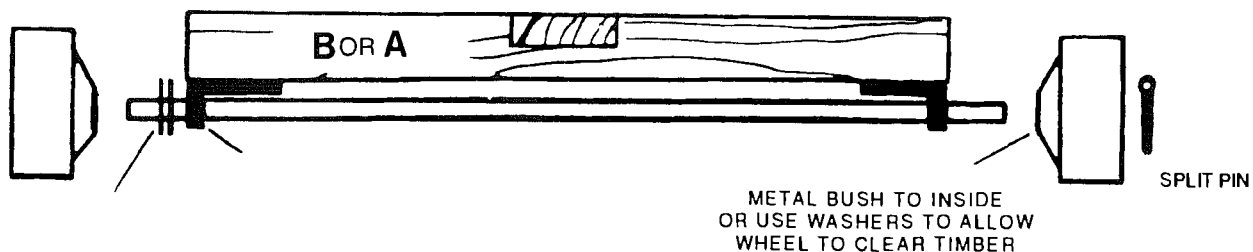

**9 Fitting footrest:** With wheels fixed, position the driver on the seat then locate the footrest, Part H onto the top of Part D. Use two nails to fit the footrest in position.

**10 The final step** is to round off all sharp corners with plane or sander and finish all over with your selected paints.

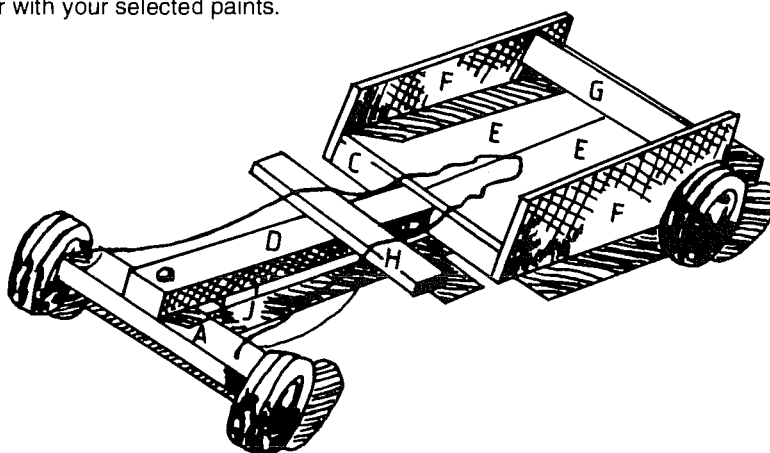

**Disclaimer:** While the Timber and Building Materials Association (NSW) Limited (**TABMA**) and its members believe this publication is an invaluable guide to this project, the Association cannot guarantee that every statement is without flaw. Therefore, the Association and its members hereby disclaim all liability for errors or omissions of any kind, whether they be negligent or otherwise, or for any loss, damage or other consequence which may arise from any person relying on information stated in this publication.

This brochure was prepared with the assistance and co-operation of the Timber Development Association NSW Ltd.

For further information see [www.timber.net.au](http://www.timber.net.au)

Copyright Owner: Timber and Building Materials Association (NSW) Limited

**Supplied by**